

TIPS & TRICKS

DECKING AND FACADE
CONSTRUCTION

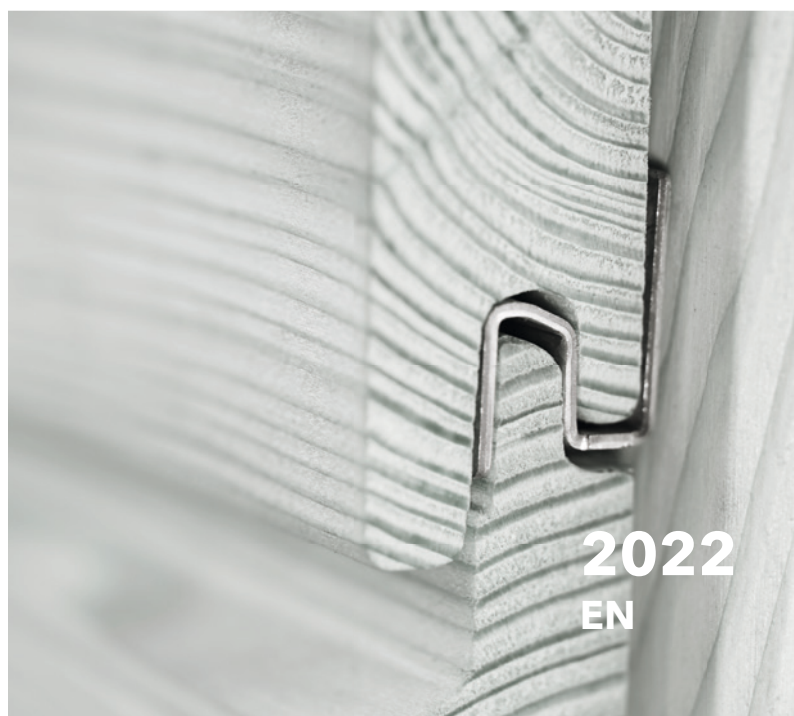

2022
EN



TIPS AND TRICKS DECKING CONSTRUCTION

SUBSTRATE AND SUB-CONSTRUCTION SETUP

The substrate for the decking substructure must ensure a durable and frost-proof load-bearing surface.

To ensure proper water drainage, there must be a sufficient slope or drainage system in place. The substrate must not allow water to build-up. [waterlogging].

For an aggregate base layer of gravel or crushed stone the following must be used, load-bearing concrete slabs [e.g. pavement slabs 20 x 20 x 4 cm] must be laid underneath the load-bearing points [e.g. pedestal].

A protective membrane is placed underneath the base layer to prevent against unwanted vegetation growth.

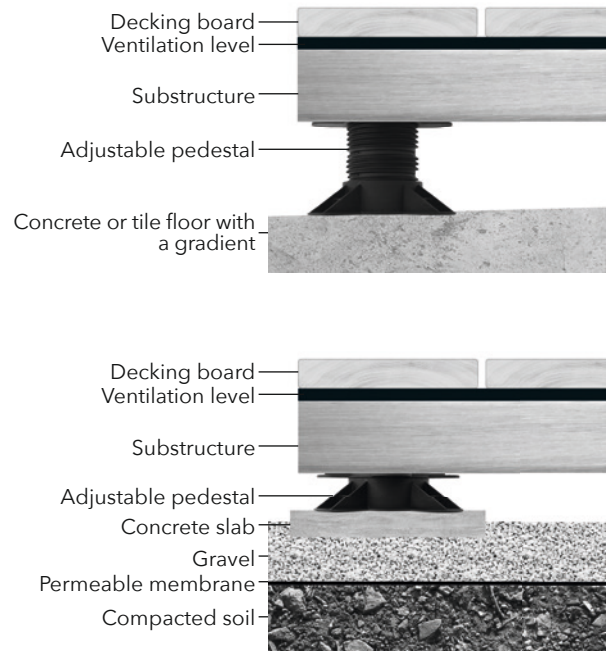

Load-bearing points are to be designed in such a way that maximum stability is achieved on a permanent basis. Load-distributing concrete slabs [pavement slabs] must be placed level and compacted into the base layer.



A structure height of 100 mm ensures optimum ventilation to the entire construction. Poorly ventilated terraces can lead to problems such as boards cupping and partial failure of the fasteners.



Side panels around the perimeter should allow ventilation to the entire construction, e.g., with the RELO V ventilation grate. Closed side panels e.g., decking boards prevent sufficient ventilation and may limit the longevity of the terrace construction.



VENTILATION AND DRAINAGE

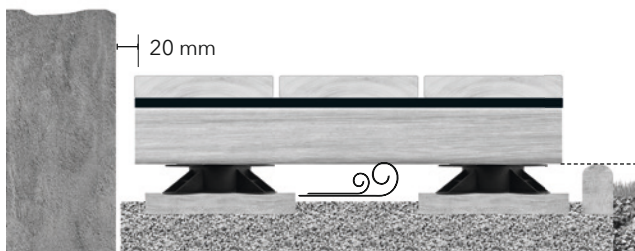

The perimeters must allow sufficient ventilation to the entire construction. A distance of min. 20 mm is required from the adjacent object.

The decking substructure should ideally be above any adjacent landscape edging.

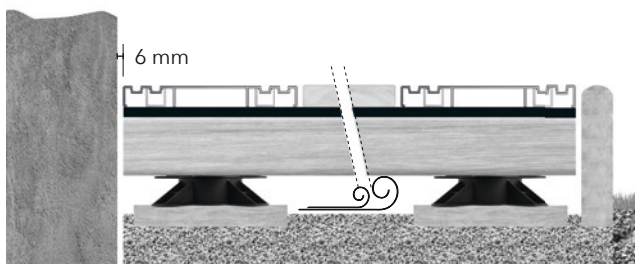

The distance from the adjacent structure can be reduced from 20 mm to 6 mm with the RELO V ventilation grate.

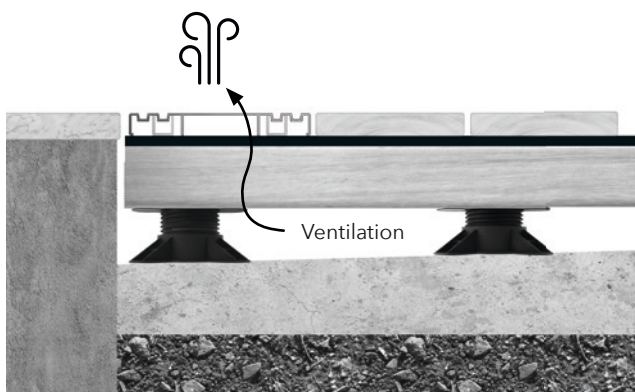

When extending the decking or perimeter edging made of stone, concrete, or ceramic tiles [at the same height level as the decking], ventilation sections are to be used to ensure adequate ventilation. If this is not possible a distance of at least 20 mm is required.

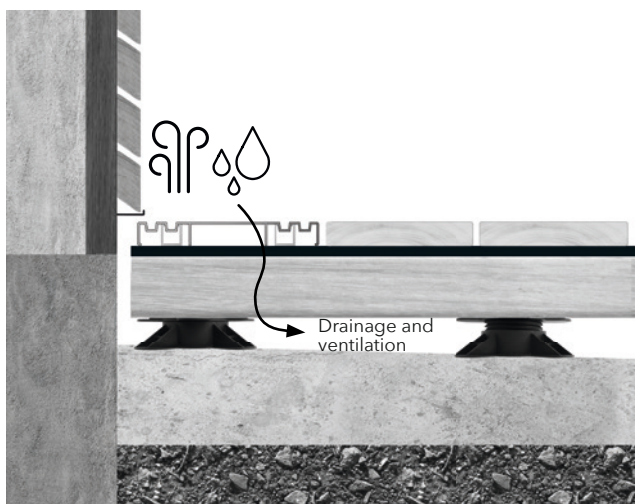

Along adjacent structures such as facades and sliding or folding doors, etc., ventilation drainage grates should be used for ensuring proper ventilation, water drainage, and reduction of dirt contamination from water spray.



TIPS AND TRICKS DECKING CONSTRUCTION

GENERAL INFORMATION

The distances between the supports must be determined so that bending of the substructures are prevented – excessive distances between supports can cause deflection when walking over, thus leading to additional stresses acting on the decking fixtures causing them to fail.

Recommended payloads:
Private use $\approx 4 \text{ kN/m}^2$
Public use $\approx 6 \text{ kN/m}^2$

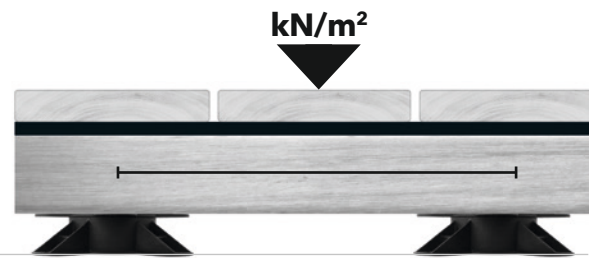

A minimum clearance of 6 mm [ventilation level] enhances Structural integrity, reduces the swelling and shrinking movements of the boards and reduce the shearing effects on the fasteners – direct surface contact wood on wood should be avoided.
e.g. with BASO or GUMO D.

50% less shearing force on wooden substructures
30% less shearing force on aluminium substructures

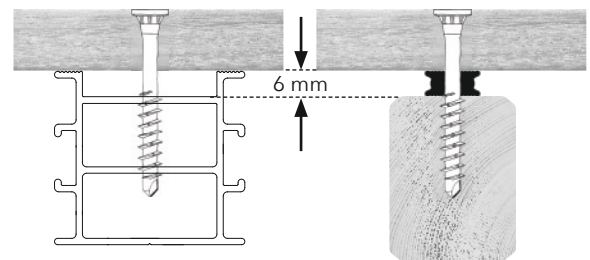

The wood moisture content % must be checked before installing the boards. The correct moisture content of the decking ensures a trouble-free and long-lasting terrace. The correct wood moisture content is to be specified by the wood supplier.

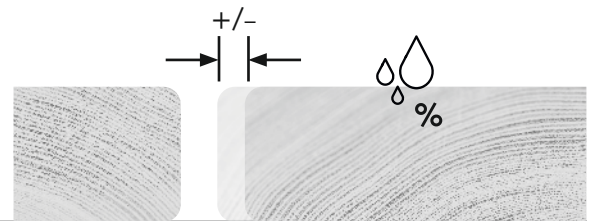

Wood is a naturally grown material. Warped and/or twisted decking boards must be sorted out during installation or if possible used as short planks

When specifying the qualities and grades, typical wood characteristics should be considered.

Environmental influences and exposed locations can influence the wood properties and characteristics.

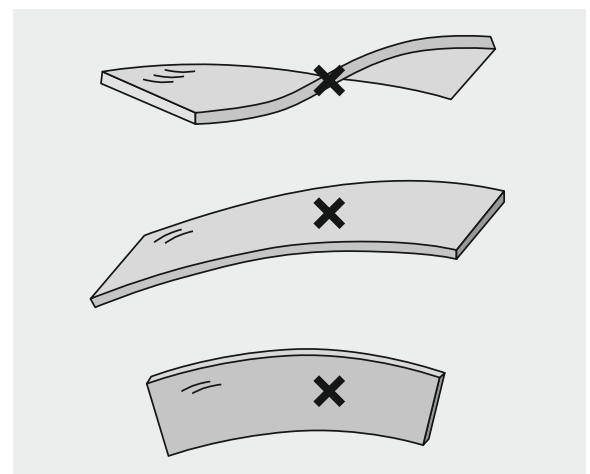

There are various reasons for laying the boards on the right or left side facing upwards depending on the production process, type of wood specie and profiling. The correct side of the board should always be laid upwards.

Installing boards on different sides can later result in visual defects and failure of the fastening system.

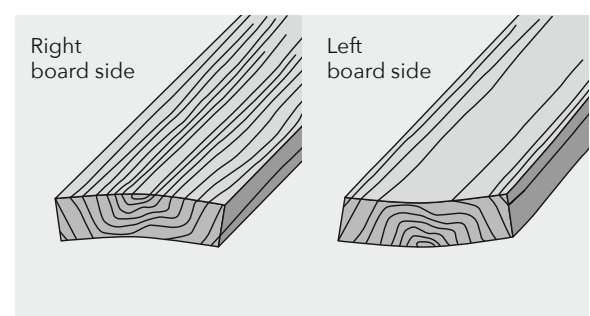

SUBSTRUCTURE



The substructure must be exactly leveled and aligned. Irregularities in the substructure lead to subsequent faults and early damage to the entire decking construction including the fastening technology. Irregularities are transferred directly to the fixings.

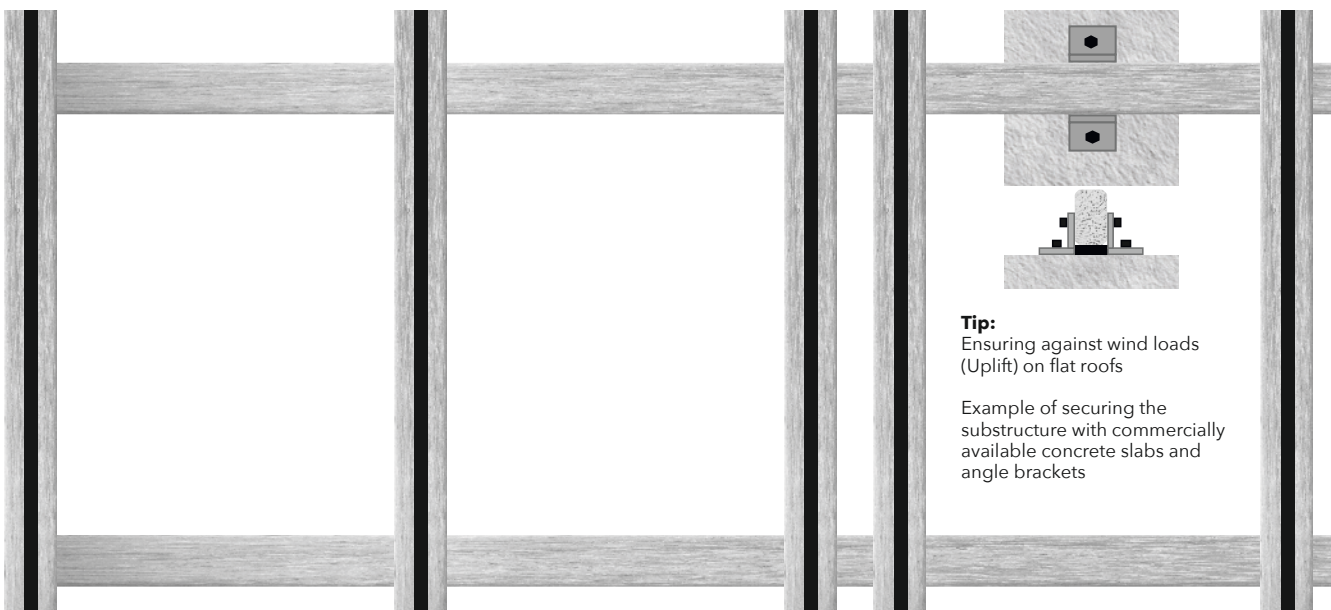

If a substructure cannot be securely anchored to the ground [subfloor], a rigid structure, e.g., by means of a frame construction or counter-batten construction must be implemented. These construction methods will ensure the terrace stays flat in position and prevents lifting of support bearing points, especially around the perimeter.

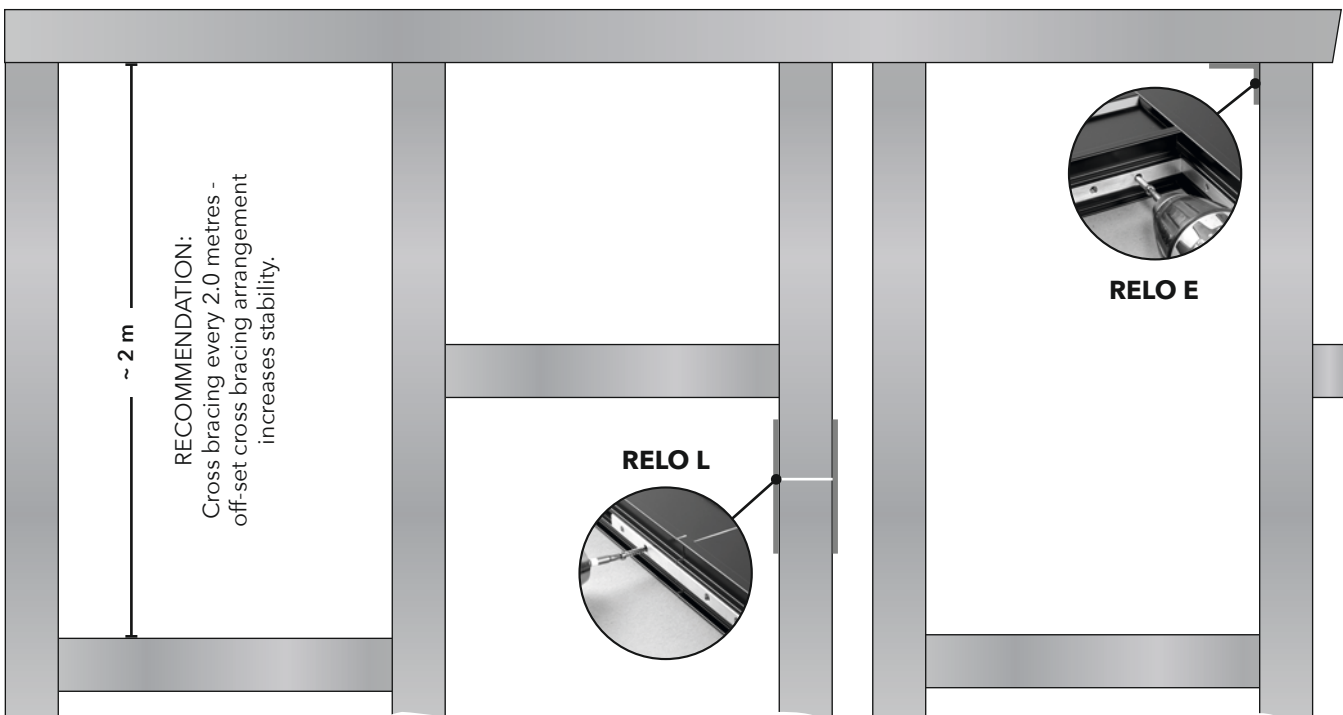

Rigid frame construction with securely fastened corner and lengthwise connections using RELO E and RELO L brackets. The installation and alignment of the substructure is considerably simplified by this design.





The substructure for terrace construction can be made of wood, wood-like material or aluminium.

For wooden substructures attention must be paid to durability and dimensional stability. Bowed and/or warped substructures must be sorted out during installation or, if possible, used as cross bracing for frame constructions.

Substructures made of wood, especially imported wood, can have a very high density [kg/m^3] - check in advance whether the fasteners are compatible.

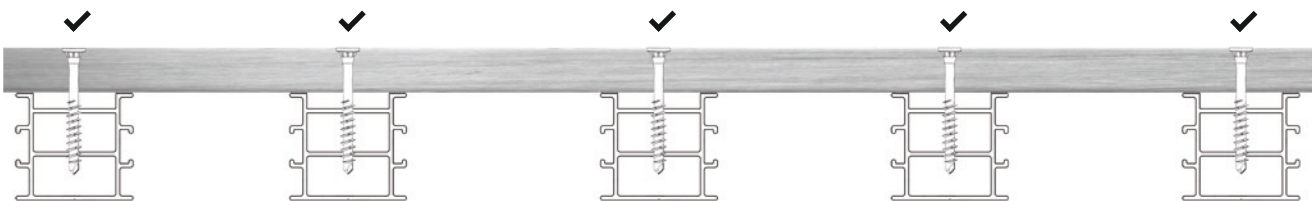

Aluminium substructures offer absolute dimensional stability, are distortion-free and resistant to weathering.

For aluminium substructures, the compatibility of the decking board with the fastener is of great importance.



Center distance:
 400 mm for board thicknesses upto 23 mm
 450 mm for board thicknesses more than 24 mm

The centre distances must be adhered to for timber and aluminium substructures regardless of the fastener. If the centre distances are too large there will be an increased shear force per fastener which in turn may not be able to withstand the dimensional changes and the deformation force of the boards.

Short boards **Y** should be mounted to at least 3 substructures .

BUTT JOINT DESIGN AND DISTANCES

The screw distance from the board edge should be between 15 - 25 mm depending on the board width. The screw distance from the end of the board should be between 50-80 mm. If the distance from the end of the board is too far the boards will twist and warp, if the distance is too small cracks will form.

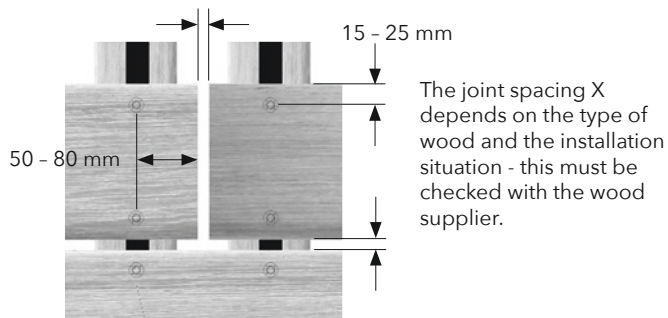

The board end joints mounted only to one substructure increases the moisture absorption in the end grain which leads to excessive swelling and shrinkage of the boards and promotes dirt build-up. Additionally the necessary distance for the screws from the board ends cannot be achieved.



PRE-DRILLING

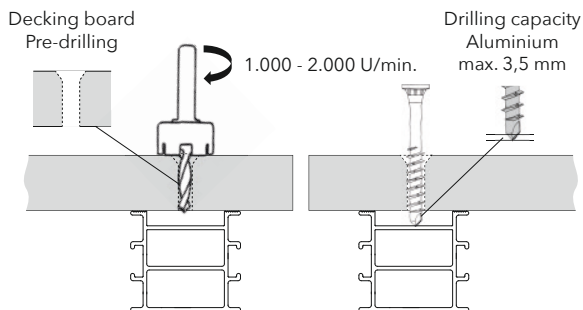
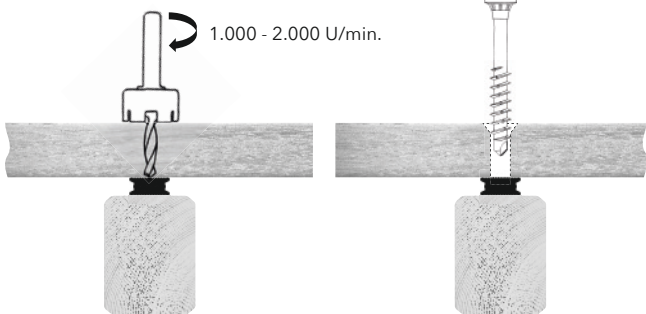

The board to be connected is with a pre-drill and countersink tool pre-drilled and countersunk. To avoid possible staining of the wood in proximity of the screw head, the accumulated drilling dust must be removed immediately after pre-drilling. The bit should be replaced after a longer period of use in order to avoid any iron abrasion. Tip: Do not use a magnetic bit holder, this attracts metal particles and leads to staining [iron-tannic acid reaction] on the board. Existing staining can be removed with special cleaning agents.

SCREW ARRANGEMENT

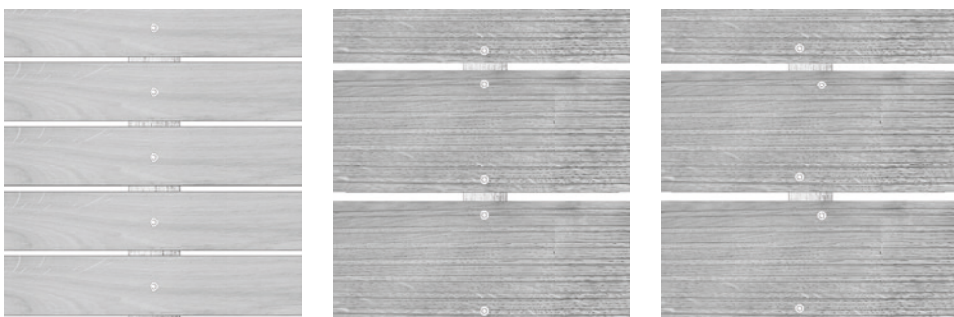

When the board width \leq 70 mm, we recommend one mounting screw

When the board width \geq 70 mm, we recommend two mounting screws

The screw layout can be aligned or offset

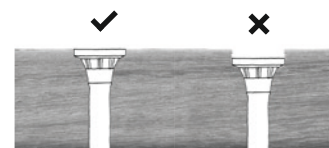

The screws should be countersunk flush with the head. Screw heads that are recessed too deep will encourage the accumulation of dirt and water - this can lead to staining around the screw head.



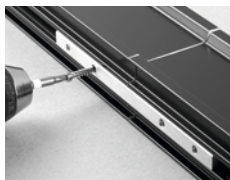
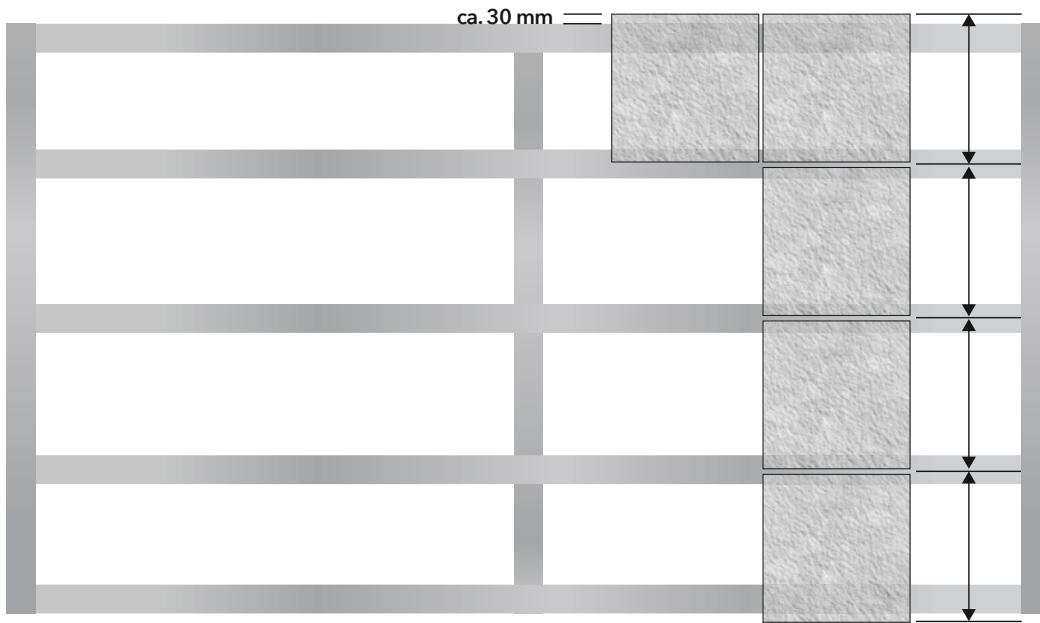

The frame construction is designed to match the dimensions of the tiles/ slab, using RELO E corner brackets and RELO L longitudinal ensures a secure and rigid construction.

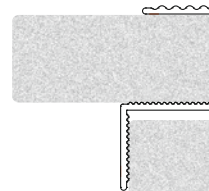

The outer rows of tiles should protrude approx. 30 mm so that the RELO RA edge finishing trim profiles can be attached.

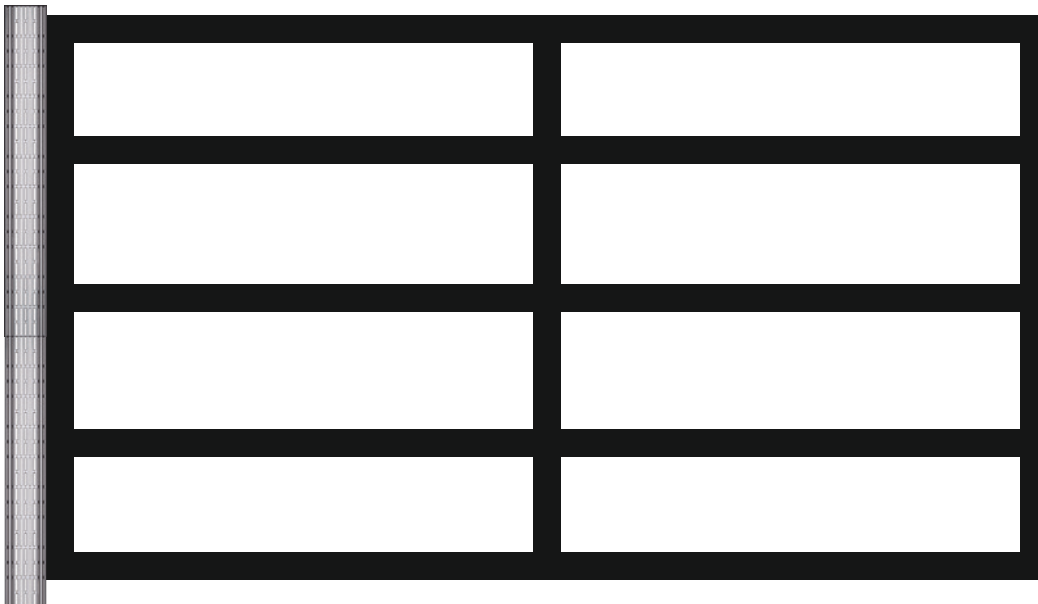

A RELO V ventilation drainage grate must be used for adjoining objects.

The ventilation drainage grate allows optimum water drainage and reduces splash back from contamination on adjacent objects.

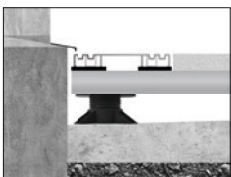

The GUMO LGR 3 mm Underlay is installed by rolling along the substructure frame.

The underlay is anti-slip and provides a shock absorption effect between the aluminium substructure and ceramic tiles.

The rubber underlay should be bonded at intervals to the substructure with a suitable mounting adhesive.

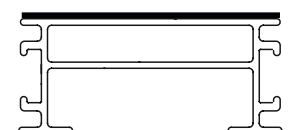

TERRACE STONE TILES INSTALLATION

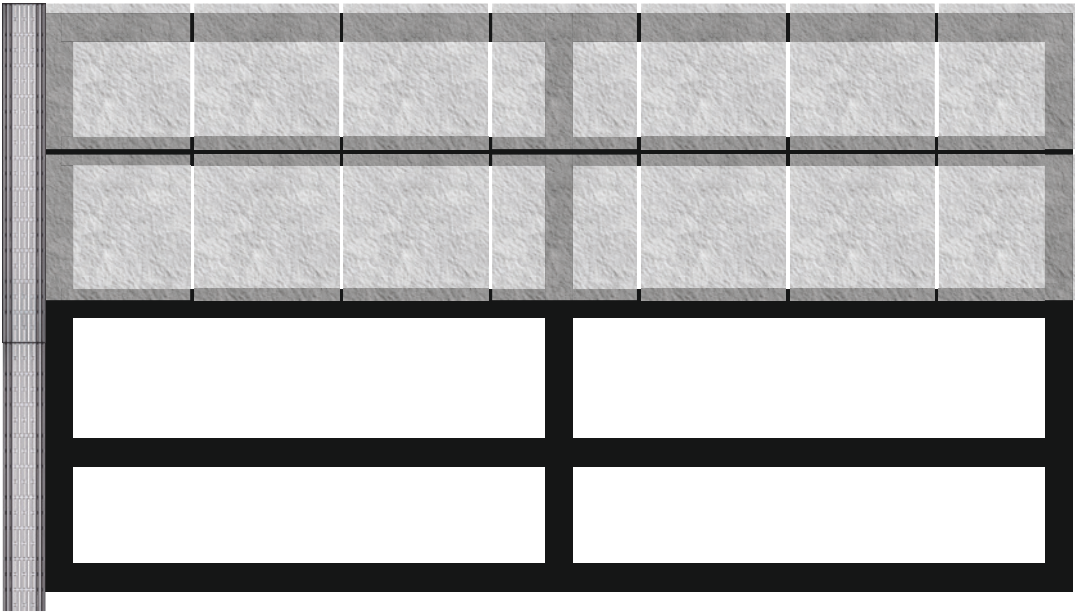

The terrace stone tile joints are set out as required using commercially available tile joint spacers.

The joint cross spacers can be divided or quartered depending on the connection point.

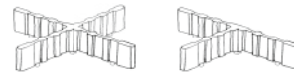

TERRACE STONE TILE WITH LIFTO KS

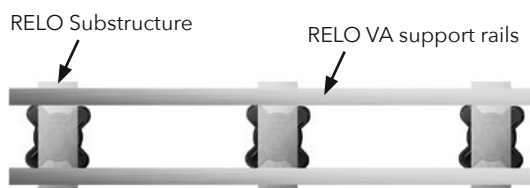
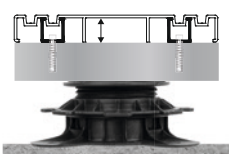
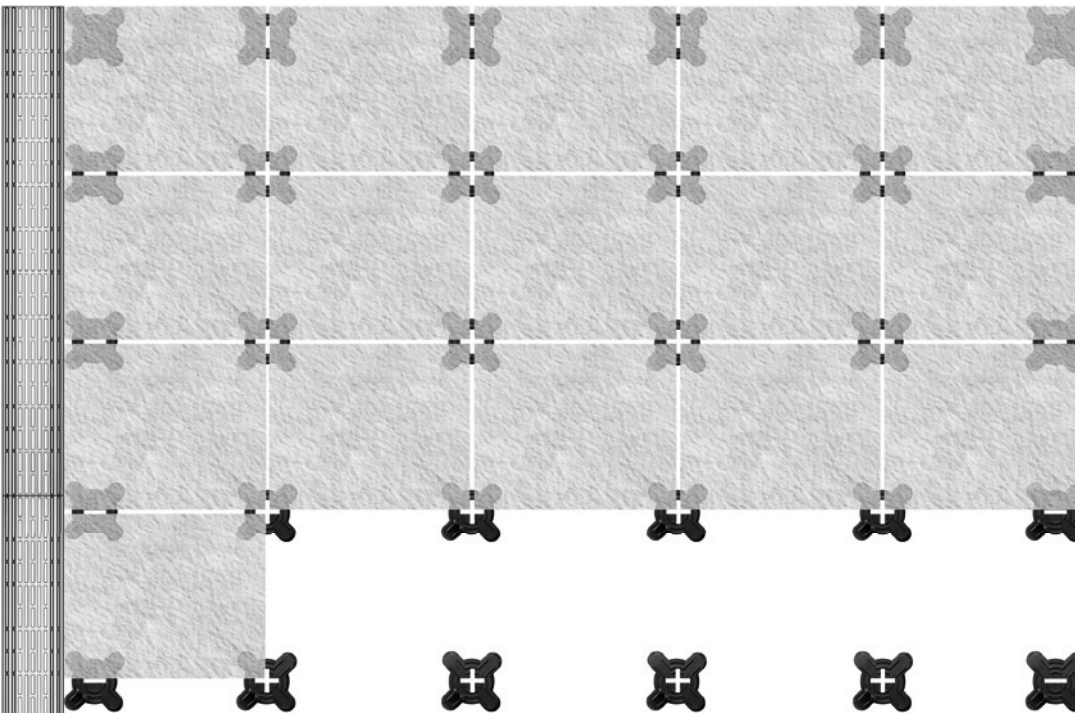

The RELO V ventilation drainage grate can be securely screwed together with a RELO substructure and the RELO VA support profile. [Cut length 150 mm].



The ventilation profile is then mounted on the support profiles.



TIPS AND TRICKS CLADDING CONSTRUCTION

ARRANGEMENT AND DISTANCES OF FASTENERS

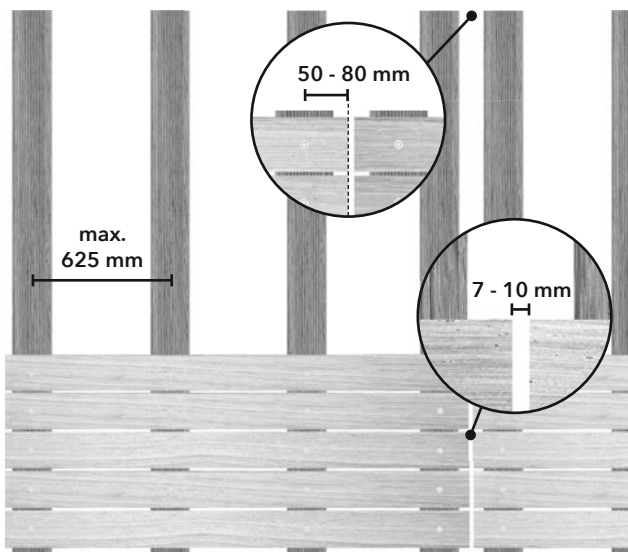
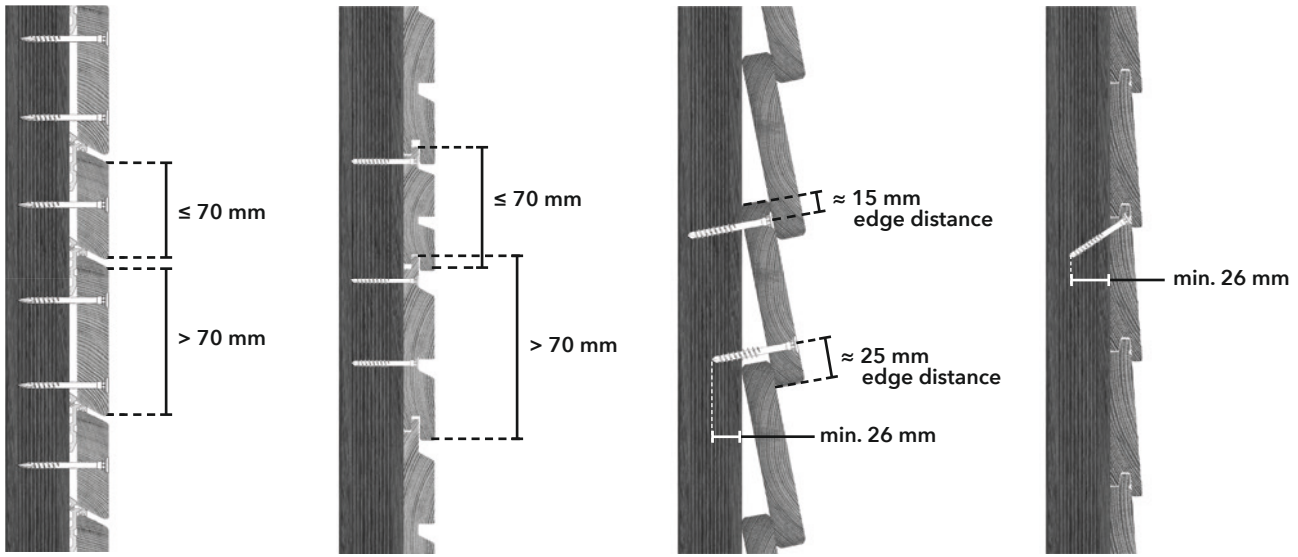

Horizontal mounting

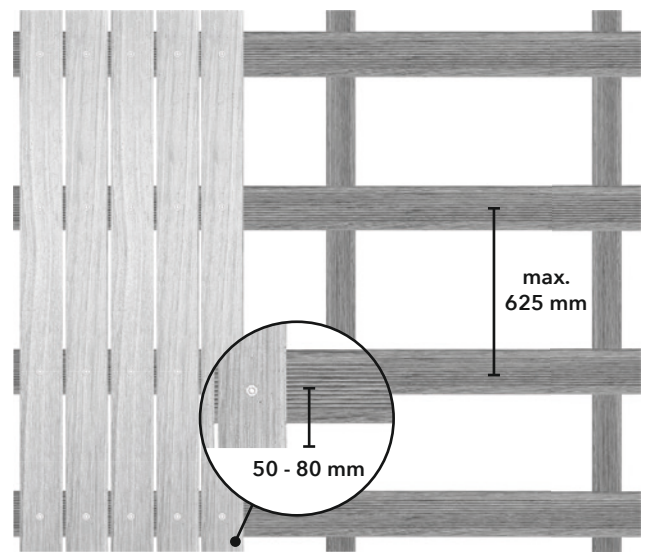

Vertical mounting

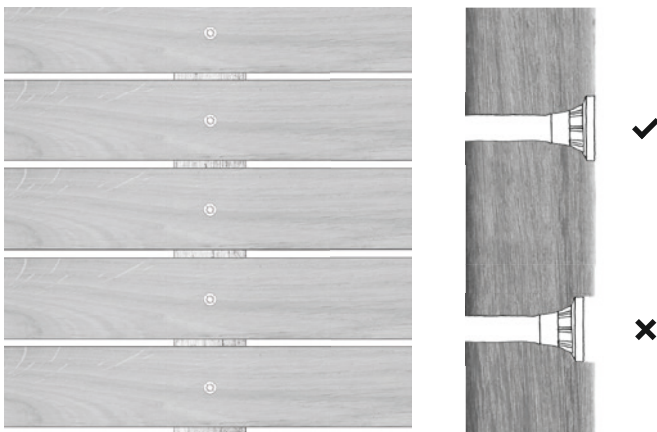

The screw heads should be countersunk flush with the mounting surface.

Too deep recessed screw heads promote the accumulation of dirt and water - this can lead to discoloration and promote mould growth on the facade surface.

DESIGN OPTIONS BASE AND ROOF CONNECTIONS

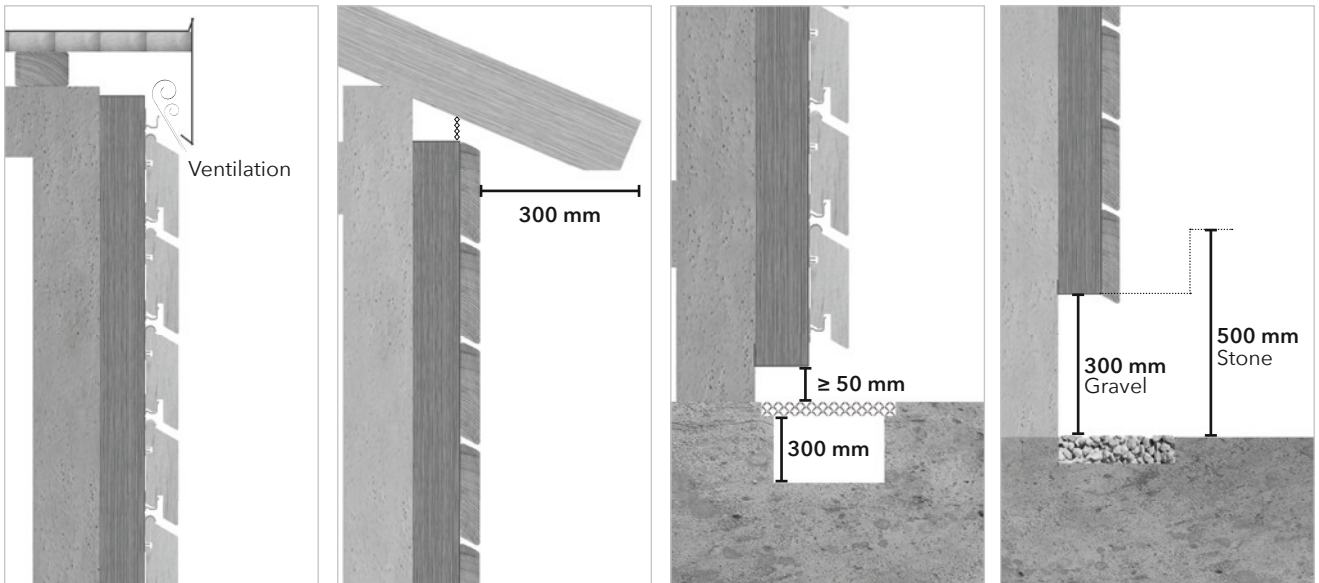

DESIGN OPTIONS VERTICAL JOINTS

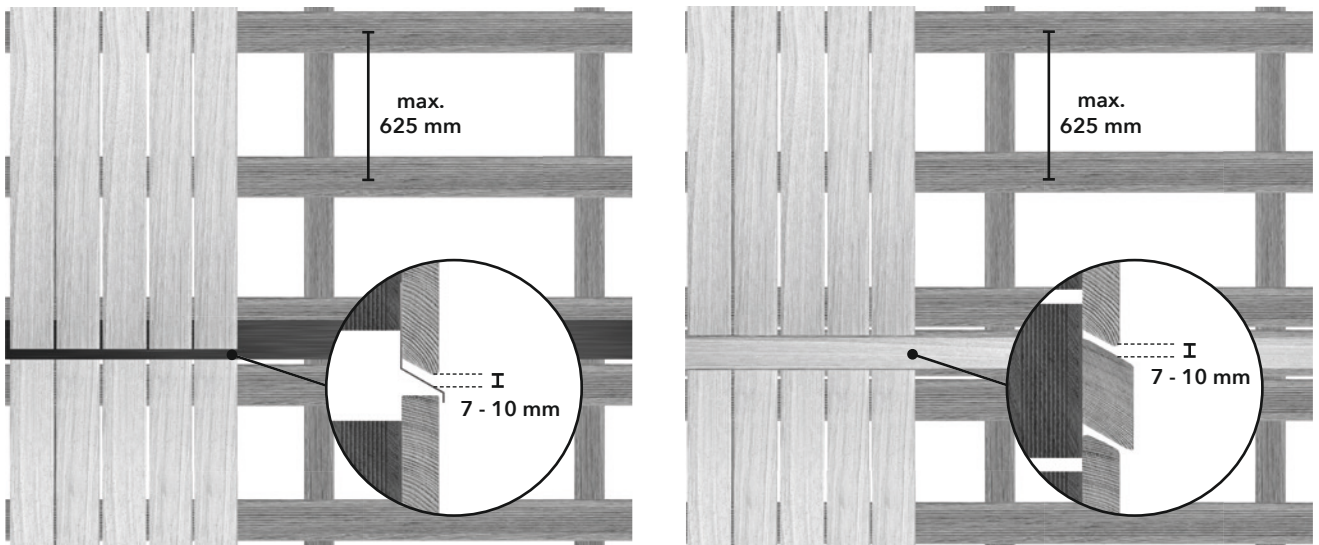

DESIGN OPTIONS CORNER JOINTS

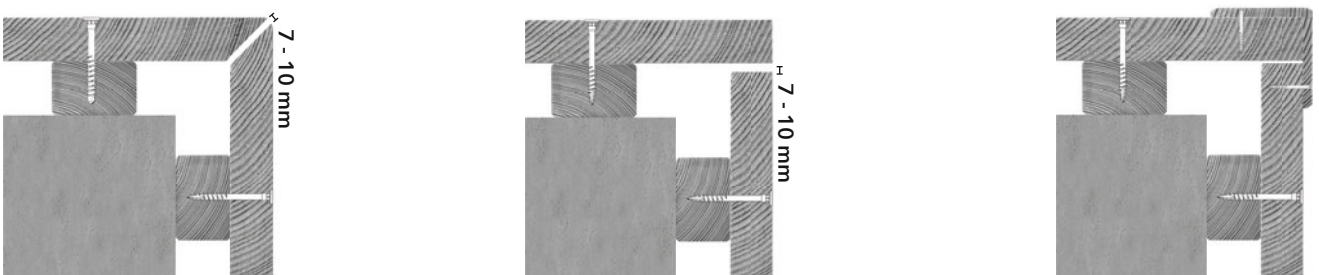

PREMIUM FIXING SYSTEMS FOR YOU

Tips & Tricks provides important fundamental information, details and application recommendations in advance to prevent complaints and claims due to non-conforming designs.
Tips & Tricks do not replace country-specific regulations, subject rules, guidelines and standards.

Errors and technical alterations are subject to change.
Liability for printing mistakes or defects are excluded.

Concept and content:

FIXINGGROUP GmbH, A-4912 Neuhofen im Innkreis, Gobrechtsham 176